

OV1013 | Part No. 80161



OV1013

HEIGHT ADJUSTABLE TABLE

USER GUIDE

OV1013

HEIGHT ADJUSTABLE TABLE

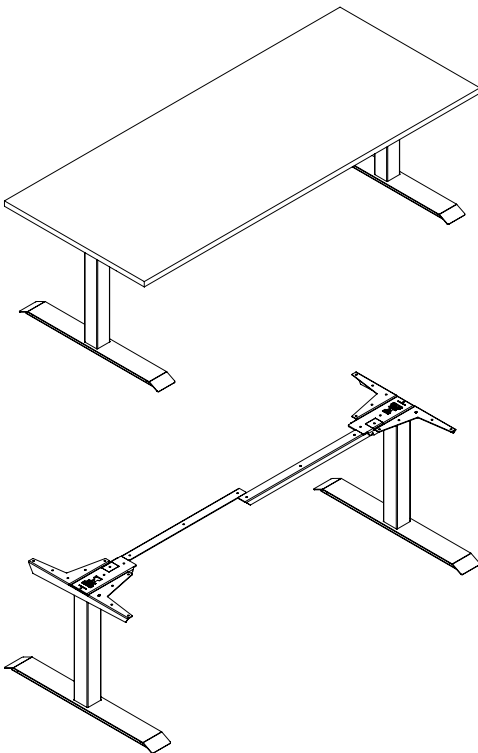

A healthier work environment starts with the option to sit or stand throughout the day. Our OV1013 table is the industry standard in height-adjustable products, and the first step towards improving the efficiency and well-being of any organization.

The OV1013 is designed with the motor built right into the column, resulting in a tight profile to the table top. A stand-alone solution, this table was created to offer a more sleek look for both corporate and residential markets. The kit supplies everything you need to assemble your height-adjustable table base. Just add your own work surface to personalize.

FEATURES

- Meets BIFMA X5.5 standards
- Adjustable frame
- Over 150 color options
- Holds up to 200 lb. load

TABLE OF CONTENTS

Parts Diagram	4
Safety Information	5-6
Assembly Instructions	7-9
Operation	10-11
Troubleshooting	12-13
Customer Service	14
Standards & Certifications	15

This manual explains how this sit-stand desk is assembled, used, and maintained. All sit-stand tables are subjected to functional and quality tests before leaving our facility.

OV1013

PARTS DIAGRAM

FULL LENGTH

For tables 48" - 72"

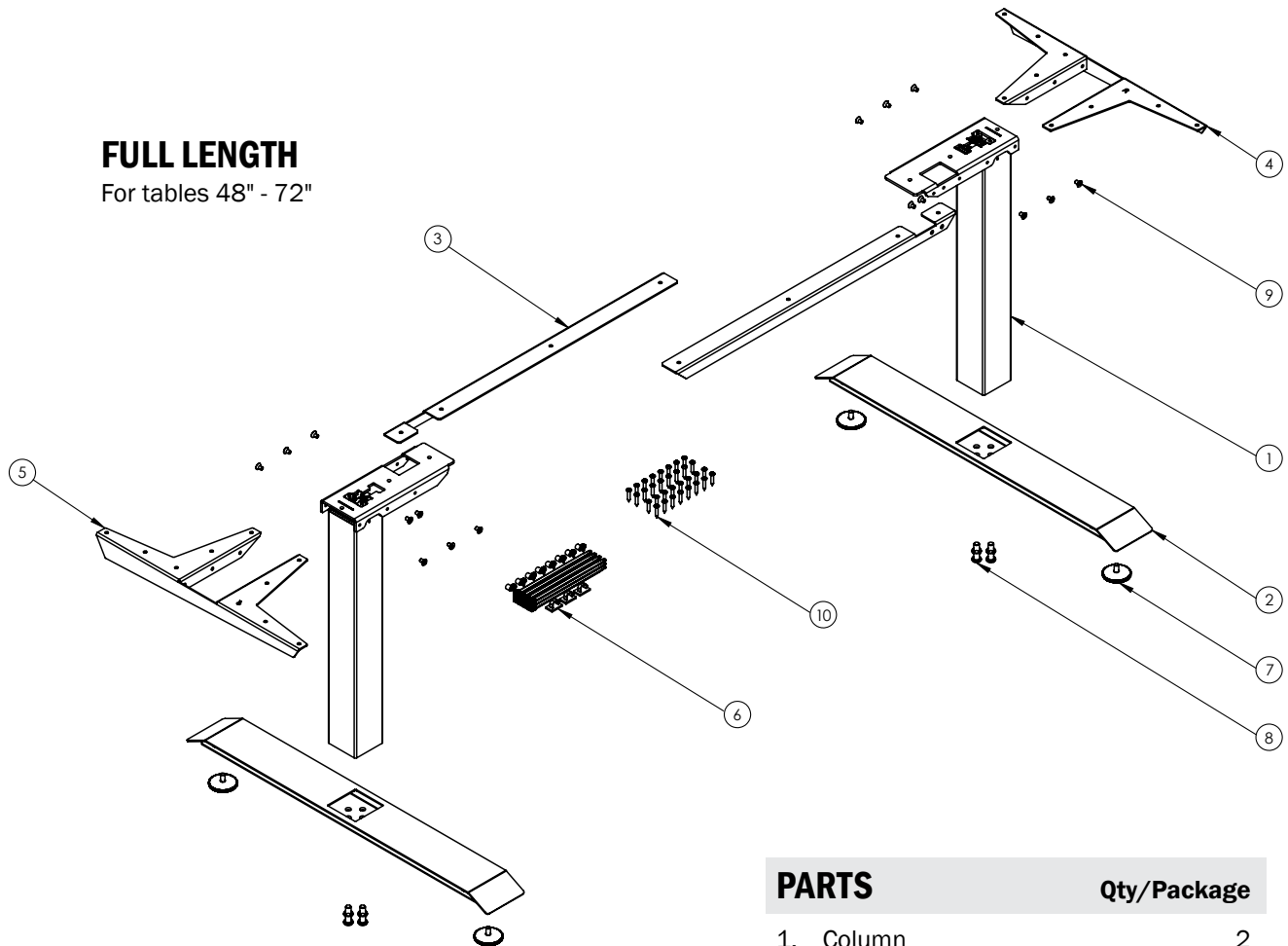

PARTS

Qty/Package

1.	Column	2
2.	Foot (24" or 30")	2
3.	Support Rail	2
4.	Top Support-Right Hand	1
5.	Top Support-Left Hand	1
6.	Wire Management Kit	1
7.	Glide	4
8.	M10 x 14mm Button Head Screw	4
9.	M6 x 10mm Flat Head Screw	20
10.	#10 x 1" Wood Screw	34

SAFETY INFORMATION

IMPORTANT SAFETY INSTRUCTIONS *Save these instructions.*

DANGER To reduce the risk of electric shock:

Always unplug this furnishing from the electrical outlet before cleaning.

WARNING: To reduce the risk of death, serious injury, or property damage, read and follow this safety information and the provided instructions when assembling this product. Do not change or replace components and accessories provided by OMT-Veyhl.

INSTALL ONLY APPROVED WORK SURFACES

This table system does not include a work surface (desktop). Work surface must be at least $\frac{3}{4}$ " thick and weigh no more than 5 lb. per square foot (For example, a 2'x6' desktop should weigh no more than 60 lb). Do not exceed a maximum weight for the desktop of 75 lb. To prevent table from tipping or collapsing, make sure the desk frame is not overloaded by the weight of tabletop and objects you plan to put on the table. If you are unsure, contact customer service.

KEEP AWAY FROM CHILDREN

This table system is not designed for use in homes or other areas accessible by small children. For indoor commercial office use only.

BE CAREFUL WHEN ADJUSTING DESK HEIGHT

Body parts and property can be caught between the moving work surface and an immobile obstacle (such as shelves, furniture, window sills, or walls). Keep at least one inch of clearance around desk and make sure nothing is in table's path for its entire range of motion.

Before raising or lowering:

- Check surroundings on all sides of desk are clear
- Make sure corded objects will not be pulled off table or cause other objects to fall
- Make sure desk power cord moves freely as desk moves up and down

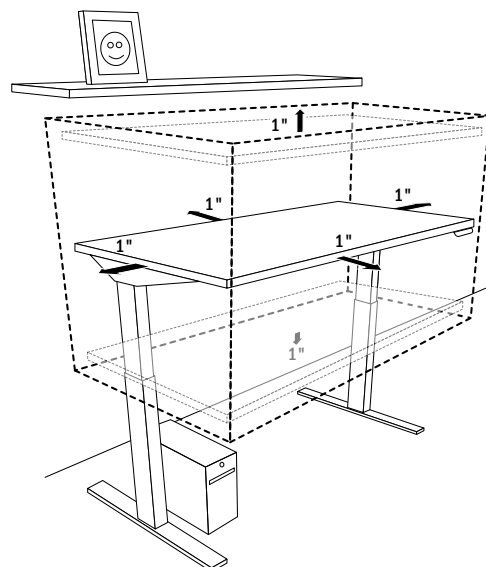

DO NOT OVERLOAD DESK

To prevent table from tipping or collapsing, make sure the desk frame is not overloaded by the weight of tabletop and objects on table. Evenly distribute load; excess loads near edges can reduce stability and lead to tip over.

- Do not exceed maximum load (including weight of desktop) of 200 lb. (91Kg)
- Do not exceed edge load of 25 lb. when positioning monitors or mounting accessories.
- Do not sit or stand on table

USE CARE WHEN MOVING DESK

- Clear objects and equipment from table before rolling to reduce the risk of tipping over.
- Adjust the desk to its lowest height before moving
- To disconnect, turn all controls to the off position, then remove plug from outlet
- Do not move a loaded desk
- Do not lift the desk by the work surface (desktop)

DO NOT OPEN ELECTRICAL COMPONENTS

Do not attempt to service table components. There are no user-serviceable parts inside the motor control units or table legs. If your table needs service, contact customer service. Never operate this furnishing if it has a damaged cord or plug, if it is not working properly, or if it has been dropped or damaged. Return the furnishing to a service center for examination and repair.

KEEP TABLE FRAME DRY

Keep all electrical components away from water and high humidity. Clean only with a dry or slightly damp cloth. Do not spray cleaning solutions directly onto table system.

GROUNDING INSTRUCTIONS

This product is equipped with a cord having an equipment-grounding conductor and a grounding plug. **Use only the cord provided.** Make sure that the product is connected to an outlet having the same configuration as the plug (as shown in Illustration A) that is properly installed and grounded in accordance with all local codes and ordinances.

Do not modify the plug provided with the product – if it will not fit the outlet, have a proper outlet installed by a qualified electrician.

No adapters are to be used with this product.
Keep cord away from heated surfaces.

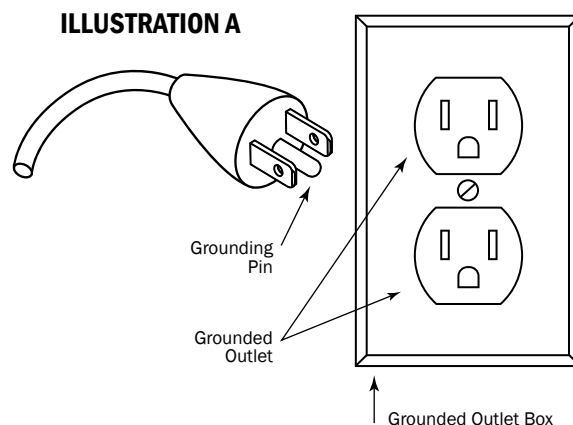

ASSEMBLY INSTRUCTIONS

The assembly of the table frame to be made in accordance with this manual.
Changes to the table frame or improper use may affect the safety, function, and life of your product.

This manual is for all sit-stand tables from the OV1013 series.

ASSEMBLY OVERVIEW

1. Assemble the top supports to the columns
2. Assemble the rail to the columns
3. Fasten the table frame onto the table top
4. Assemble the feet to the columns

If you have any difficulty assembling this unit, or need to order replacement parts, please contact our Customer Service department.
Use the parts diagram on page 4 as a reference.

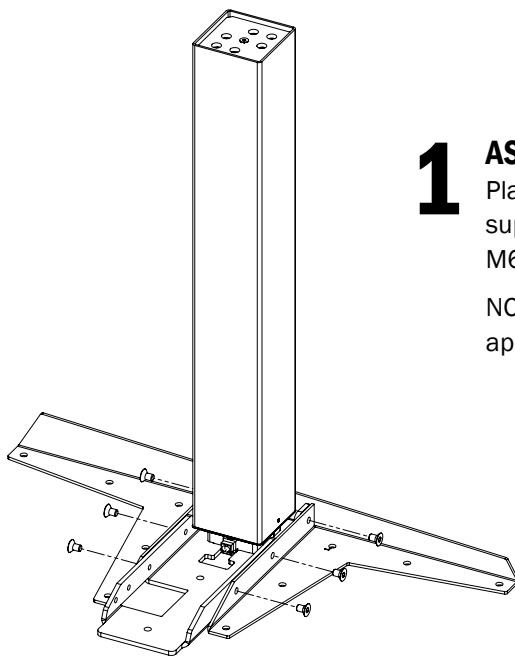

1 ASSEMBLE THE TOP SUPPORTS TO THE COLUMN

Place column upside down on work surface. Place top support around column and assemble using the provided M6 x 10mm flat head screws.

NOTE: Be sure to assemble using the top supports on the appropriate sides (right and left).

2 ASSEMBLE THE RAIL TO THE COLUMN

Fit the support rail onto the column mounting plate using the provided M6 x 10mm flat head screws.

NOTE: Insert screws to support rail from the inside of the rail.

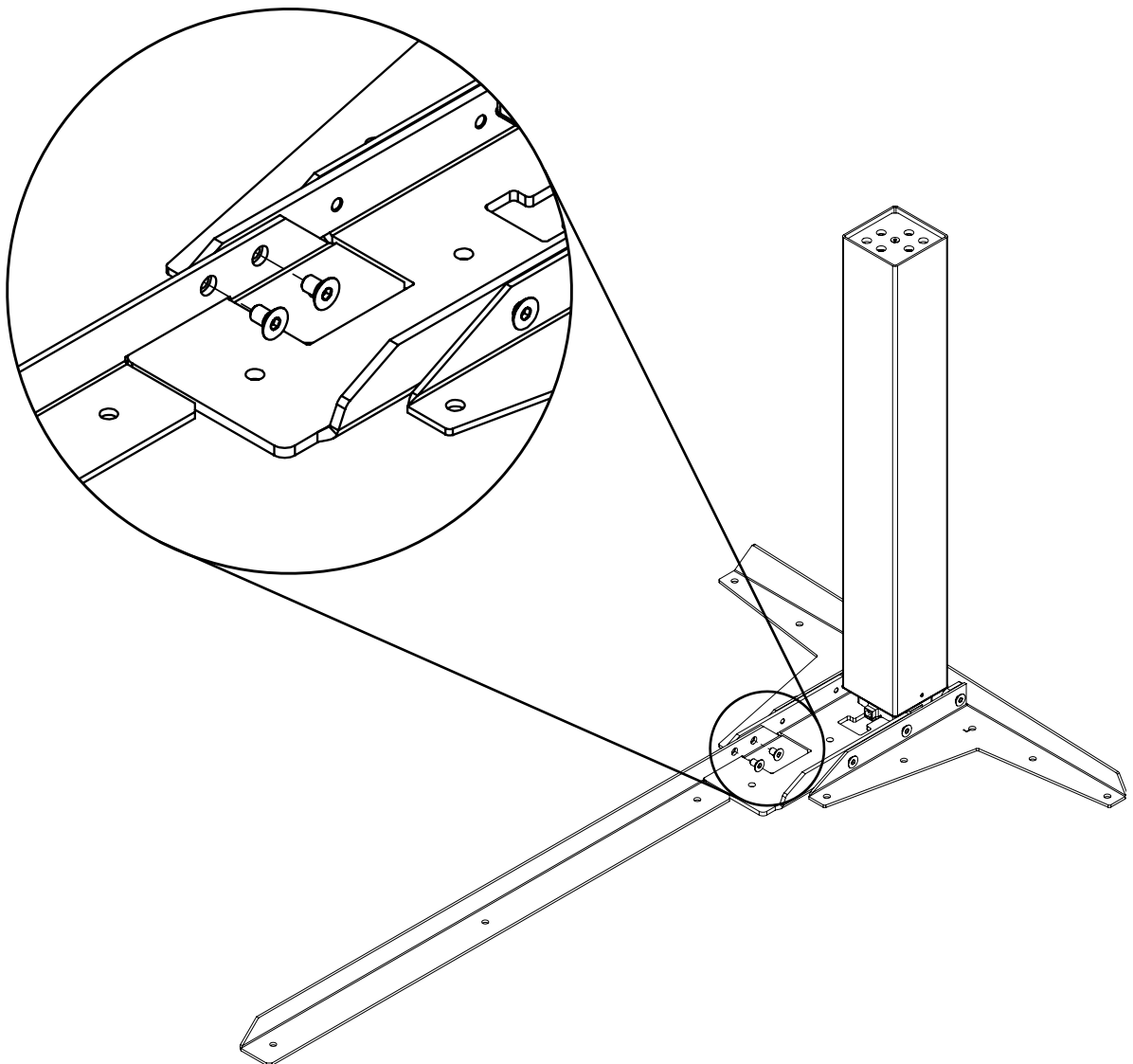

3 FASTEN THE TABLE FRAME ONTO THE TABLE TOP

Position columns on the table top. Drill $\frac{3}{32}$ " pilot holes using the #10 x 1" wood screws provided.

NOTE: Reference Safety Information on page 5-6 before proceeding.

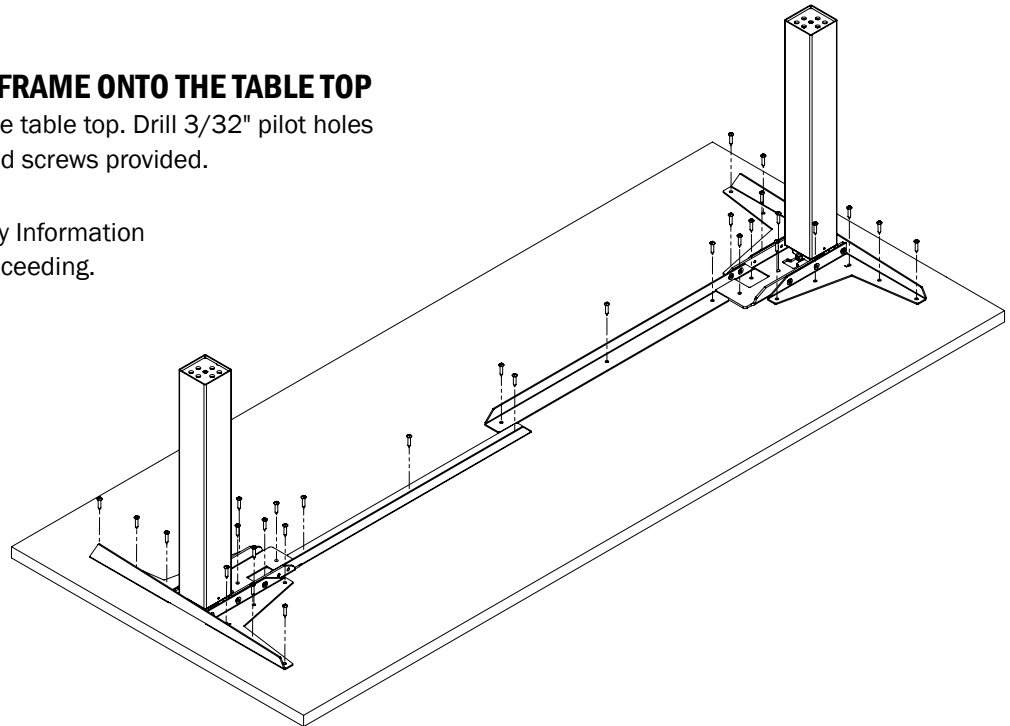

4 ASSEMBLE THE FEET TO THE COLUMNS

Place feet on ends of columns and fasten using the provided M10 x 14mm button head screws. Tighten to 35 ft-lb (48Nm).

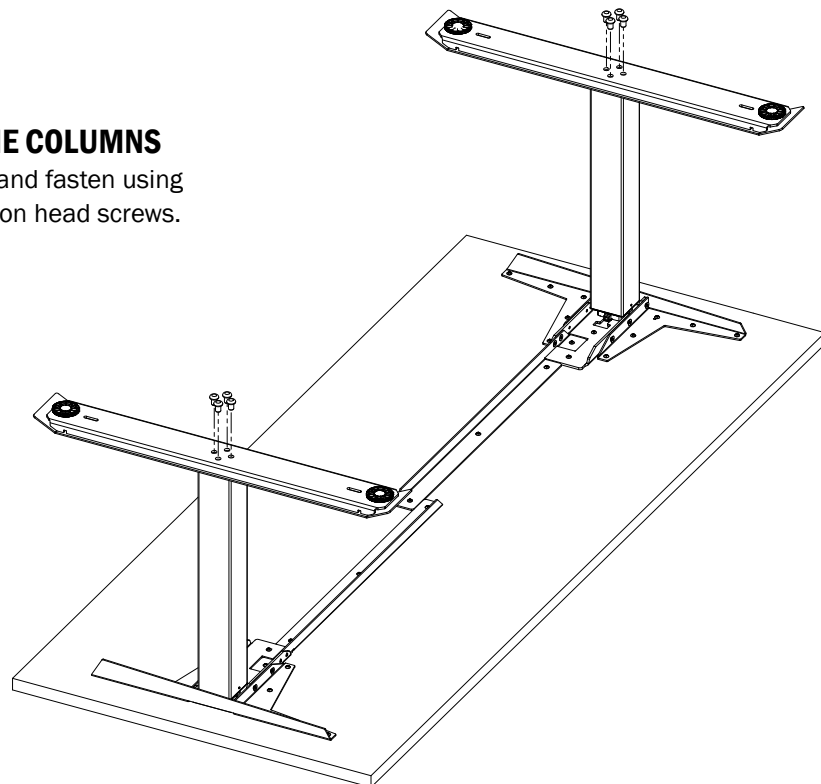

OPERATION INFORMATION

INITIALIZATION/RESET

The desk may need to be initialized/reset after any of the following:

- After assembly
- After disconnection from the power supply
- After any impact on the table top.

To initialize/reset, you will need to move the table to the lowest position by holding the DOWN button of the handswitch until all columns reach the lowest position. Then press the DOWN button again and hold it pressed for five seconds or until a slight movement of the table drops down to the machine zero point and back up to the operation zero point. Once the table stops moving, release the DOWN button. If the button is released too early, this leads to a malfunction of the table and you must repeat the reset process.

The upper height position is programmed into the control box. For this reason, only use the control box that has been provided with the specific table frame. **Under no circumstance should a control box from one table be moved to another.**

NORMAL HANDSWITCH OPERATION (for all handswitch types)

By pressing the UP or DOWN buttons, the table will move up or down to the desired position. Once the desired position is reached, let go of the UP or DOWN button. The table will stop once it reaches the lower or upper height position.

PROGRAMMABLE HANDSWITCH OPERATION (optional)

This programmable handswitch is equipped with a display for showing the current table height in centimeters or inches.

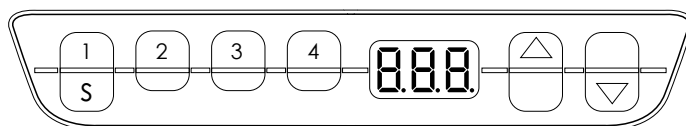

The handswitch also will display an error code if an error is detected by the control box. When an error is detected, the display will show an error code “EXX,” instead of the current table height. To resolve the error, see the Troubleshooting Section (p. 16-17 of this guide).

The programmable handswitch also has the ability to save up to four different height positions.

PROGRAMMABLE HANDSWITCH OPERATION (continued)

CHANGE THE HEIGHT UNIT (inches or centimeters)

The height display of the handset can display either centimeters or inches. With the help of the S5-menus, the unit can be changed. If the display was originally set to centimeters, then after the procedure noted below it will change to inches or vice versa.

To change the unit, follow these steps:

1. Press and hold the 1, 2, and UP buttons for 5 seconds until the display shows “S 5”.
2. Confirm by pressing the “S” button. Now the display will have changed.

To exit the menu without making a selection, wait approximately 10 seconds until the height display appears again.

ADJUSTMENT OF THE HEIGHT DISPLAY

If the indicated value does not match the actual height of the table top, the display can be corrected as follows:

1. Press and release the “S” button.
2. Press and hold the DOWN button for 5 seconds until the display starts to flash.
3. Measure the table height and enter the measured value (depending on the setting in centimeters or inches) with the UP or DOWN button. Confirm the entry by pressing the “S” button.

To exit the menu without making a selection, wait 10 seconds and the height display will appear again.

SAVE MEMORY POSITION

Drive the table up or down to the desired height. Press the “S” button (in the display “S -” is shown.) Select a position by pressing on any of the four number buttons, 1-4, (the display will show the setting as “S1”). The save position procedure is confirmed by the control box with a double click sound. After approximately 5 seconds, the display shows the current table height. Repeat steps to save a maximum of four different positions.

RECALL MEMORY POSITION

Press and hold the desired memory location button (1, 2, 3 or 4) and the table moves independently from the current position into the saved position. The button must be pressed until the position is reached. If the button is released, the table will stop short of the desired height.

TROUBLESHOOTING

UNIT

ERROR CODE	SOURCE	SOLUTION
Table does not move	No power supply	Plug in the power cord or check the connection on the control box
	No connection or a loose connection to the drives	Verify the plug connections of the motor cable to the control box
	No connection or a loose connection to the handswitch	Verify the plug connections of the motor cable to the control box
	Max lifting capacity is exceeded	Reduce the weight or load on the desktop
	Max time limit is exceeded	Control is activated automatically after approx. 9 minutes
	Defective drive	Contact customer service
	Defective control box	Contact customer service
	Handset is defective	Replace the handset
Table moves down at a slow rate	Control box expects new reset	Reset control box. (See page 10)
During operation, tables moves at a slow rate	Max lifting capacity is exceeded	Reduce weight
Table moves on one side only briefly and then stops	No connection or a loose connection to the drives	Verify the plug connections of the motor cable to the control box and reset the control box
	Defective drive	Contact customer service

HANDSWITCH DISPLAY

ERROR CODE	SOURCE	SOLUTION
HOT	The control box monitors the duty cycle (time-controlled) and its max temperature. A value has been exceeded.	Wait until the "HOT" display goes out - the table is working properly again
E00	M1 - Internal Fault	Unplug and contact customer service
E01	M2 - Internal Fault	
E02	M3 - Internal Fault	
E12	M1 - Defect	Unplug. Correct the external short circuit and/or verify the cable to the drives. Plug cables into the control box and re-run table.
E13	M2 - Defect	
E14	M3 - Defect	
E24	M1 - Overcurrent	Collision → resolve if necessary
E25	M2 - Overcurrent	Max load exceeded → remove excess load from the table
E26	M3 - Overcurrent	If the problem still exists, please contact customer service
E36	M1 - Not connected	Motor not connected. Check cable / connector to the drive. Reset the table (see page 10).
E37	M2 - Not connected	
E38	M3 - Not connected	
E48	Overcurrent drive 1	Collision → resolve if necessary
E49	Overcurrent drive 2	Max load exceeded → remove excess load from the table
E55	Drive 1 - Synchronization is lost	If necessary, reduce the load on the table
E56	Drive 2 - Synchronization is lost	Reset the table (see page 10)
E60	Collision identified	Option ISP function. Remove source.
E61	Drive replaced	The connection to the drive is interrupted or a new drive is connected. Reset the table (see page 10).

If it is not possible to resolve an error as described, disconnect the power cord, wait a few minutes and reset the table again. If the error still occurs, remove the table from the power source and contact customer service.

(Error Code list is valid from firmware 1.7.5 and higher)

CUSTOMER SERVICE

If you have any problems with your table base, please contact our service department.

PHONE: 1-616-738-6688

FAX: 1-616-738-6682

STANDARDS & CERTIFICATIONS

Meets 2014 BIFMA standards.

WARRANTY

CONTACT YOUR SALES REPRESENTATIVE FOR WARRANTY INFORMATION

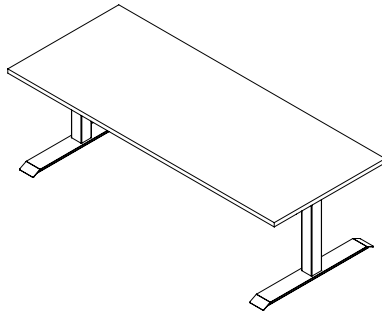

OV1013

USER GUIDE

Part No. 80161