

ORDERING A CLEVER TABLE FROM THE STANDARD SOL

When ordering a single table (Clever), you need the following:

1. CHOOSE COLUMN KIT

- Single Stage 2 Leg Configuration
 Dual Stage 3 Leg Configuration
 Up/Down Switch
 PGM Switch

2. NEED A HAT-CHANNEL KIT?

- Length of Top: _____
 No HAT Channel (for widths less than 69")
 HAT Channel (for widths greater than 69")

3. CHOOSE FOOT KIT

- T Foot 24" Glides
 C Foot 30"

4. CHOOSE COLOR

- Standard Provide Color Code _____
 Custom Fill out Custom Color Request Form
 Color Match Provide sample to Sales, ship to address below

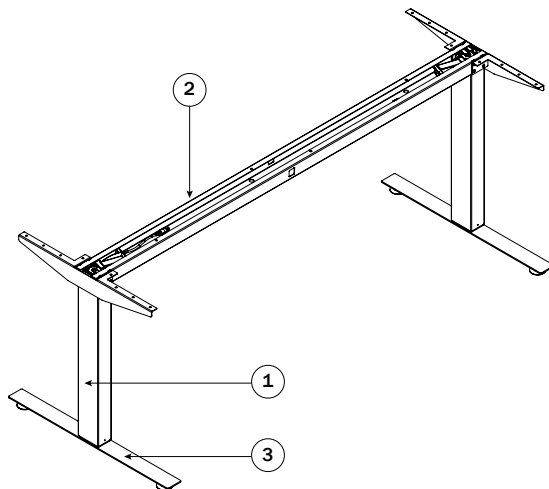

PO CHECKLIST

Send PO to orders@omt-veyhl.com

See PO Help Sheet.

- Part numbers with matching descriptions
 OMT-Veyhl color code
 Ship-to address
 Clearly stated order title (ex. MOCKUP or REPLACEMENT)
 Date of PO submission
 Request date of delivered product
 Additional information (ex. box label requirements)

Once we receive the complete PO, Customer Service will respond within 48 hours.

Orders for standard product will have a formal acknowledgment with a promised ship date within 48 hours.

Orders for new (unreleased product) may take longer to acknowledge due to engineering and/or database structuring.

**SEE SOL FOR PRICING
OR CALL SALES AT 616-738-6688**



11511 James Street • Holland, MI 49424 • 616.738.6688 • omt-veyhl.com

Terms of Use: The user is responsible for determining the suitability of OMT-Veyhl products for specific applications. © OMT-Veyhl 2017

v 083017