



## Product Specs

# ASCEND

## HEIGHT ADJUSTABLE WORKSTATION

### FEATURES

- ✔ Single and dual monitor configurations
- ✔ Electric lift
- ✔ Integrated wire management
- ✔ Tools provided for easy assembly



## ADDITIONAL INFORMATION

- Single stage height adjustability up to 18.9"
- Raising/lowering speed 1.5" per second
- Monitor mounts hold up to 24" screens
- 35 lb. tray lift capacity
- Bumper pad protected work surface
- Wire management for monitor cords
- Meets ANSI/BIFMA X5.5 standards
- Custom-designed, tray-integrated sit-to-stand switch
- Power consumption <0.3W

## OPTIONS

### MONITOR MOUNT OPTIONS



Single Monitor Configuration



Dual Monitor Configuration

### POWDER COAT COLOR OPTIONS



Textured Black



Textured White

### WARRANTY INFORMATION

**Three Years** Electronic components such as control boxes, handswitches, motors.

**Five Years** Mechanical components such as crank drives, spindles.

**Ten Years** Structural components such as beams, feet and top supports.

## TECHNICAL SPECIFICATIONS

TYPE	STROKE LENGTH (IN)	HEIGHT MIN / MAX (IN)	TRAVEL SPEED (IN/sec)	MAX WEIGHT (LB)
Single Stage	18.9	25.75/44.5	1.5	35

### DRAWING

Standard Dimensions

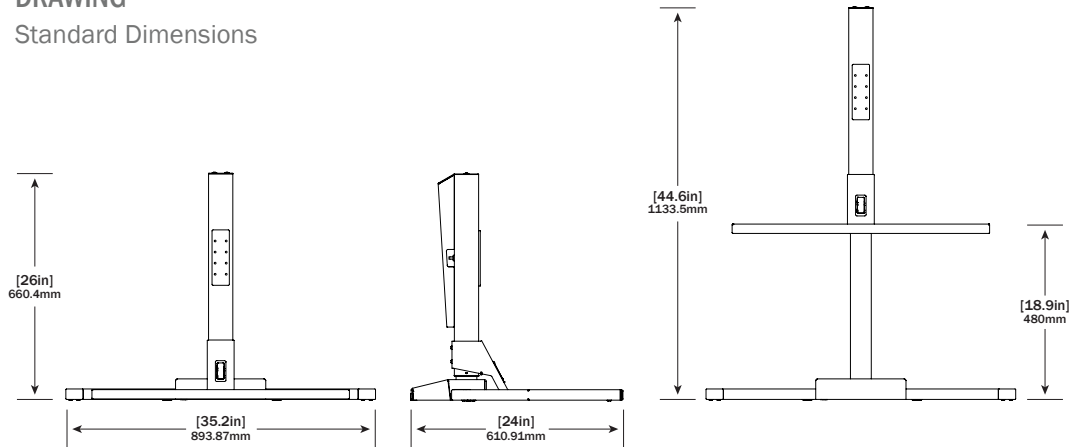

### NOTES

- Workstation width: 35.2"
- Workstation depth: 24"
- Tray dimensions: 13.25" x 29.25"
- Dual monitor maximum weight: 32 lb.
- 1.25" incremental adjustments (3.75" overall adjustment)
- Patent pending