



Product Specs

FAST CRANK TABLE BASE

FEATURES

- ✔ Full table base (add your own work surface)
- ✔ Adjusts at 1.125" with each crank revolution
- ✔ Over 150 color options
- ✔ Zero energy consumption



ADDITIONAL INFORMATION

- Raising/lowering speed 1.125" per one crank revolution
- Rectangular columns only
- Available as a single stage, two-column base only
- Supports 36" to 72" table widths
- Zero power consumption
- Crank handle slides inward to store underneath table top when not in use

OPTIONS

FOOT OPTIONS



T Foot

POWDER COAT COLOR OPTIONS

150+ colors available.

ADJUSTABILITY OPTIONS



Fast Crank

WARRANTY INFORMATION

Three Years Electronic components such as control boxes, handswitches, motors.

Five Years Mechanical components such as crank drives, spindles.

Ten Years Structural components such as beams, feet and top supports.

TECHNICAL SPECIFICATIONS

TYPE	STROKE LENGTH (IN)	HEIGHT MIN / MAX (IN)	TRAVEL SPEED (IN)	MAX RATED LOAD (LB)	NOISE LEVEL (DB)
Fast Crank	18.3	28.5 - 47	1.125 per 1 revolution	100	N/A

DRAWING Standard Dimensions

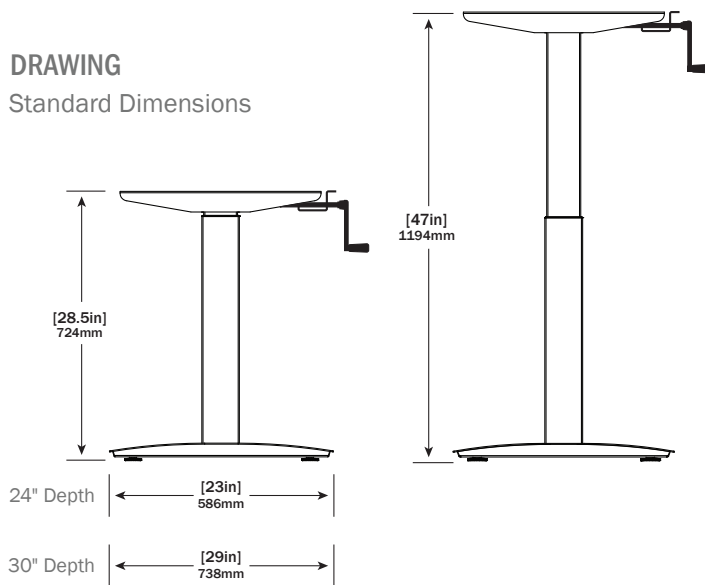

NOTES

- Base depths: 24" and 30"
- Base widths: 36", 72"
- Base heights: 28.5"–47"
- Max load: Rated load (including table top): 100 lb.
Functional load: 306 lb.