



PRODUCT SPECS

# ASCEND

## HEIGHT ADJUSTABLE WORKSTATION

**Features**

- Single and dual monitor configurations
- Electric lift
- Integrated wire management
- Tools provided for easy assembly



Sit-To-Stand Switch

## STANDARD SPECIFICATIONS

- Single stage height adjustability up to 18.9"
- Raising/lowering speed 1.5" per second
- Monitor mounts hold up to 24" screens
- 35 lb. tray lift capacity
- Bumper pad protected work surface
- Wire management for monitor cords
- Meets ANSI/BIFMA X5.5 standards
- Custom-designed, tray-integrated sit-to-stand switch
- Power consumption <0.3W

## OPTIONS

### MONITOR MOUNT OPTIONS



Single Monitor Configuration



Dual Monitor Configuration

### POWDER COAT COLOR OPTIONS



Textured Black



Textured White

### WARRANTY INFORMATION

**Three Years** Electronic components such as control boxes, handswitches, motors.

**Five Years** Mechanical components such as crank drives, spindles.

**Ten Years** Structural components such as beams, feet and top supports.

## TECHNICAL SPECIFICATIONS

| TYPE         | STROKE LENGTH (IN) | HEIGHT MIN / MAX (IN) | TRAVEL SPEED (IN/sec) | MAX WEIGHT (LB) |
|--------------|--------------------|-----------------------|-----------------------|-----------------|
| Single Stage | 18.9               | 25.75/44.5            | 1.5                   | 35              |

### STANDARD DIMENSIONS

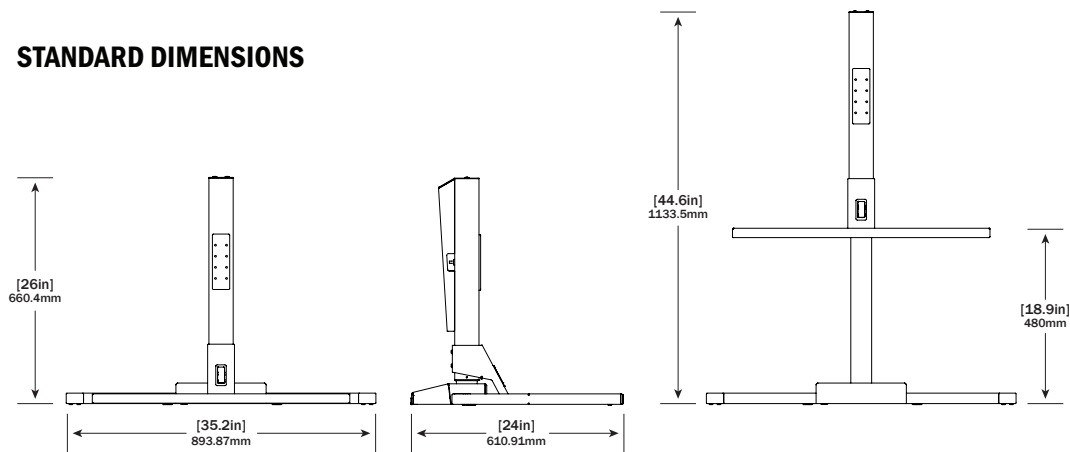

### NOTES

- Workstation width: 35.2"
- Workstation depth: 24"
- Tray dimensions: 13.25" x 29.25"
- Dual monitor maximum weight: 32 lb.
- 1.25" incremental adjustments (3.75" overall adjustment)
- Patent pending



11511 James Street • Holland, MI 49424 • 616.738.6688 • omt-veyhl.com

Terms of Use: The user is responsible for determining the suitability of OMT-Veyhl products for specific applications. © OMT-Veyhl 2020

**BUILT**  
IN THE USA

v 030520