



PRODUCT SPECS

ENTYRE TABLE

Features

- Complete table assembly
- 1" low pressure laminate surface
- Casters for easy mobility
- Optional surface-attached power strip



STANDARD SPECIFICATIONS

- Single stage height range 27.5"–46.5" (top of surface)
- Raise/lower speed of 1.375" per second
- Power consumption <0.3W
- Ships complete, just attach base to top
- Available in black, white or silver

OPTIONS

HANDSWITCH OPTIONS



Basic Up-Down

POWDER COAT COLOR OPTIONS

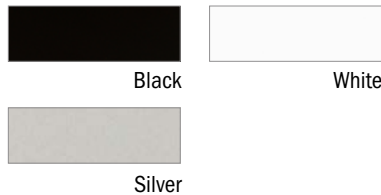

Black

White

Silver

WORKSURFACE OPTIONS

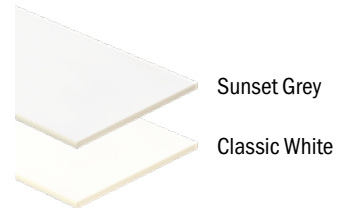

Sunset Grey

Classic White

FOOT OPTIONS



T Foot

POWER STRIP OPTIONS



Power Strip



No Power Strip

WARRANTY INFORMATION

Two Years Worksurfaces

Three Years Electronic components such as control boxes, handswitches, motors.

Five Years Mechanical components such as crank drives, spindles.

Ten Years Structural components such as beams, feet and top supports.

TECHNICAL SPECIFICATIONS

TYPE	STROKE LENGTH (IN)	HEIGHT MIN / MAX (IN)	TRAVEL SPEED (IN/sec)	MAX RATED LOAD (LB)	NOISE LEVEL (DB)
Single Stage (SSE)	19	27.5/46.5	1.375	250	<50

STANDARD DIMENSIONS

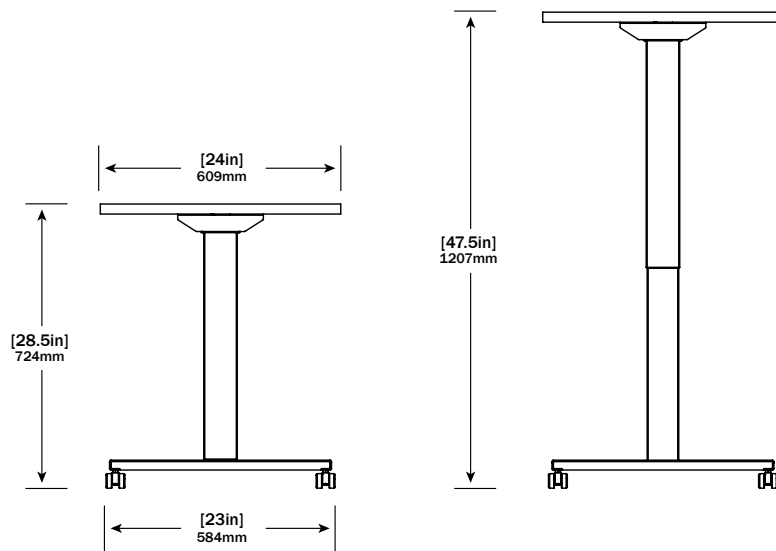

NOTES

- Base depth: 23 "
- Base height: SSE: 27.5" -46.5 "
- Worksurface size: 24" x 48 "
- Column dimensions: SSE: 3.35" x 2.17 "
- Max load: Rated load (including table top): 250 lb.



11511 James Street • Holland, MI 49424 • 616.738.6688 • omt-veyhl.com

Terms of Use: The user is responsible for determining the suitability of OMT-Veyhl products for specific applications. © OMT-Veyhl 2020

BUILT
IN THE USA

v 052620