



PRODUCT SPECS

EMPIRE
TABLE LEGS

Features

- Meets BIFMA X5.5 standards
- Ten-year warranty
- Easy assembly
- Over 150 color options



STANDARD SPECIFICATIONS

- Standard height is 27.76" without top
- Welded steel construction
- Maximum configuration size 30" x 84"
- Minimum configuration size 30" x 36"
- Includes adjustable leveling glides

OPTIONS

POWDER COAT COLOR OPTIONS

150+ colors available.

TECHNICAL SPECIFICATIONS

STANDARD DIMENSIONS

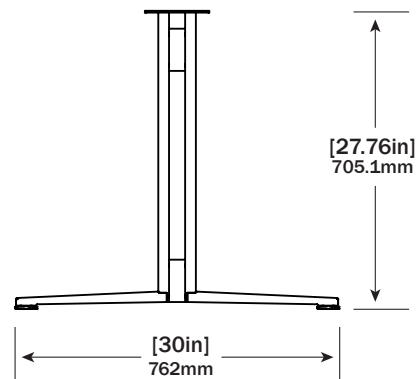





WARRANTY INFORMATION

Three Years Electronic components such as control boxes, handswitches, motors.

Five Years Mechanical components such as crank drives, spindles.

Ten Years Structural components such as beams, feet and top supports.



11511 James Street • Holland, MI 49424 • 616.738.6688 • omt-veyhl.com     

Terms of Use: The user is responsible for determining the suitability of OMT-Veyhl products for specific applications. © OMT-Veyhl 2020



v 030520